



## Nelio

Uncluttered and modern, the Nelio will naturally complete your flat screen.

Its two different finishes in *Red/Black* and *Black/Black* will make it easy to integrate perfectly in your trendy home design.

Its structure in powder coated steel can welcome a very comprehensive AV system with a perfect stability.

Its height has been optimized to insure the best comfort with screens up to 50".

The shelves in black lacquered glass give this very versatile piece of furniture an elegant and contemporary touch.



### SPECIFICATIONS

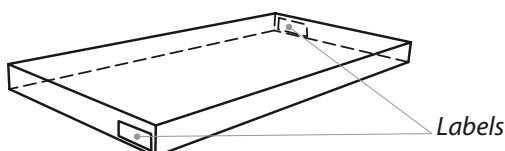
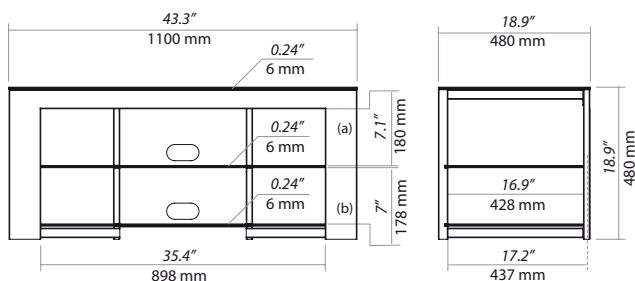
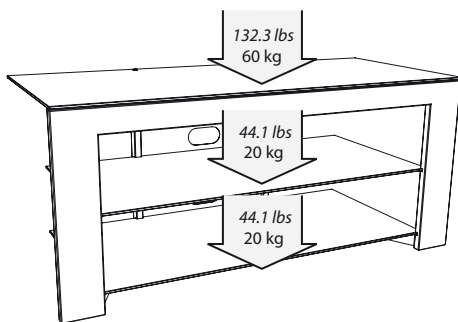

### DESIGN

**Finishes:** *Red/Black, Black/Black*

**Structure:** Powder coated steel feet (red or black) and framework

**Shelves:** Black tempered glass

**Miscellaneous:** Cable management system

### MAXIMUM LOAD

**Upper shelf:** 132.3 lbs / 60 kg

**Internal shelves:** 44.1 lbs / 20 kg

### USABLE DIMENSIONS

**Overall dimensions (W x H x D):**

43.3" x 18.9" x 18.9" / 1100 x 480 x 480 mm

**Upper shelf (W x D):** 43.3" x 18.9" / 1100 x 480 mm

**Internal shelves (W x D):** 35.4" x 17.2" / 898 x 437 mm

**Height between shelves:** (a) 7.1" / 180 mm  
(b) 7" / 178 mm

### PACKAGING

Delivered disassembled with screws kit, mounting instructions and tools

**Quantity/box:** 1

**Type:** Brown cardboard

**Dimensions (W x H x D):**

47.2" x 4.9" x 22" / 1200 x 125 x 560 mm

**Gross weight:** 69 lbs / 31,3 kg

**Net weight:** 60.6 lbs / 27,5 kg

**GenCodes:** 3760108801646 (*Black/Black*)

3760108801653 (*Red/Black*)